



3-1995

Soil salinity assessment using the EM38: Field operating instructions and data interpretation

D L. Bennett

Richard George

Arjen Ryder

Follow this and additional works at: https://researchlibrary.agric.wa.gov.au/misc_pbns



Part of the [Soil Science Commons](#)

Recommended Citation

Bennett, D L, George, R, and Ryder, A. (1995), *Soil salinity assessment using the EM38: Field operating instructions and data interpretation*. Department of Primary Industries and Regional Development, Western Australia, Perth. Report 4/95.

This report is brought to you for free and open access by the Research Publications at Research Library. It has been accepted for inclusion in Miscellaneous Publications by an authorized administrator of Research Library. For more information, please contact library@dpird.wa.gov.au.

Miscellaneous Publication 4/95
Agdex
ISSN 0725-847X
March 1995

Soil salinity assessment using the EM38:

Field operating instructions and data interpretation

By

Don Bennett, Richard George and Arjen Ryder



©Chief Executive Officer, Department of Agriculture, Western Australia 1995

Soil salinity assessment using the EM38: Field operating instructions and data interpretation

Don Bennett¹, Richard George¹ and Arjen Ryder²

¹Department of Agriculture, P.O. Box 1231, Bunbury 6230 (Phone 097 255 255)

²Department of Agriculture, 444 Albany Highway, Albany 6330 (Phone 098 928 531)

Introduction

The Geonics EM38® is a portable instrument designed to take *in situ* field measurements of soil conductivity to about 1.5 m depth. If used correctly, the EM38 allows rapid, reliable estimates of soil salinity to be obtained from large areas without intensive soil sampling. The meter is very useful for delineating the extent and relative severity of saline areas.

Although soil salinity has the dominant effect on the EM38 signal, other soil physical factors such as clay content, moisture content and temperature can affect the response. If the EM38 measurements are to be related to plant performance and used for detailed diagnostic purposes over a range of soil types, they must be calibrated with laboratory determined salinity measurements.

This report describes the correct operating, surveying and calibration procedures for the EM38.

Defining soil salinity

There is no definition of soil salinity, in chemical terms, that would satisfy all agricultural conditions. Saline soils have been defined as having a conductance of the saturation extract (EC_e - see below) exceeding 400 mS/m (Richards 1954). However, there are many factors which can affect plant response to soil salinity. These include plant species and age (rooting habit), soil moisture, soil waterlogging, climate, soil structure, and nutrient status (Northcote and Skene 1972). Therefore, saline soils are better defined as those which contain sufficient soluble salts to limit the growth of non-halophytes (Daubenmire 1974).

How the EM38 operates

The Geonics EM38® terrain conductivity meter is a portable field instrument designed to estimate soil electrical conductivity to about 1.5 m depth (rooting zone). It does this by setting up a primary



Figure 1. The EM38 being used during a transect survey at Waterloo. It is easy if one person takes the readings and the other records them in a notebook.

electromagnetic field which induces small horizontal electrical currents in the soil which induce a secondary electromagnetic field. A built-in receiver coil detects both primary and secondary fields, and it is the ratio of these two that is the measure of apparent soil electrical conductivity which is displayed in units of mS/m.

The EM38 has two modes of measurement, vertical (EM38V) and horizontal (EM38H). The theoretical depth response curves for the instrument show that 80% of the instrument response is from 0 to 1.5m in the vertical mode, and 0 to 1.0m in the horizontal mode (McNeill 1980b). This allows a quick method of assessing whether conductivities are increasing or decreasing with depth.

The usefulness of the EM38 lies in the speed and accuracy at which broadscale soil conductivity surveys can be undertaken. The photograph shows the EM38 being used to measure soil salinity along a transect at Waterloo. Up to 15 km of transect per day (measurements every 20 m) are achievable using this method. This equates to between 30 and 150 ha (lines 20 to 100m apart) of typical paddock grid survey.

Soil salinity measurement methods

The electrical conductivity of the **soil saturation extract** (ECe) is the preferred standard laboratory method for measuring soil salinity for plant response purposes. The extract is obtained by slowly saturating an oven dried and sieved (less than 2 mm) soil with distilled water, and then removing the soil water extract under vacuum. Most published plant salt tolerance information use ECe.

However, because ECe determination involves a complex laboratory procedure, many routine laboratory analyses for soil salinity are done using the easier method of the electrical conductivity of the 1:5 soil water suspension (EC_{1:5}). EC_{1:5} is obtained by mixing 10g of dried, sieved soil with 50 mL of distilled water, shaking for 24 hours and then allowing it to settle and measuring the salinity of the settled water. George and Wren (1985) published conversions to approximate ECe from EC_{1:5} for soils in south-west Australia. Their conversion is dependent on the saturation percentage (SP) of the soil (as a measure of clay content) and is given by the formula:

$$ECe = (364 \times EC_{1:5}) / SP.$$

Soil salinities obtained using the EM38 (and other instruments such as the Wenner Probe and EM31) are known as **apparent soil electrical conductivities** (ECa). ECa measurements can be converted to ECe by calibration for soil type.

As an example. Table 1 compares the soil conductivity levels at which subterranean clover (*Trifolium subterraneum*) growth would be reduced by 25%, for two soil types, for each of the three measures (George and Wren 1985). The levels are for non-waterlogged soils. A combination of waterlogging and soil salinity will increase the effect of salinity on plant growth (Barrett-Lennard 1986).

The effect of soil factors on EM38 (ECa) readings

Soil salinity has the dominant effect on ECa in most situations. Other factors which may affect ECa include clay type and content, soil moisture and soil temperature (McNeil 1980a). It is useful to know the effect these factors may have on EM38 readings to enable correct interpretation of results for plant growth or management considerations.

(i) Soil salinity

One method of determining the influence soil salinity has on ECa for any particular soil is to calibrate the EM38 with ECe using simple linear regression techniques. The square of the correlation coefficient (R) of the regression indicates the amount of variability in ECe that can be explained by ECa.

Figure 1 shows the comparison between two EM38H calibrations using sand at Boyup Brook (14 sites with an average oven dried saturation percentage of 23%) and heavy textured loams and clays from the Swan Coastal Plain (35 sites with saturation percentages ranging from 35 to 65%). The calibrations for the depth interval 0.25 to 1.00m are:

Deep Sand:

$$ECe = 4.72ECa + 112$$

$$R^2 = 0.77, P < 0.001, SE \text{ of estimate} = 70$$

Heavy Loams and Clays:

$$ECe = 3.73ECa - 56$$

$$R^2 = 0.81. P < 0.001. SE \text{ of estimate} = 100$$

Table 1. Comparison of ECe, EC_{1:5} and ECa soil salinity levels at which subterranean clover growth is reduced by 25 percent

	ECe (mS/m)	EC _{1:5} (mS/m)	ECa (mS/m)
<i>Light Sand</i>	290	20	40
<i>Heavy Loams and Clays</i>	360	45	110

The correlation coefficients for the sand and clay are 0.77 and 0.81 respectively, meaning 77% and 81% of the variability in soil salinity can be explained by ECa.

Other calibrations of the EM38 are available. For example, Ferdowsian and Greenham (1992) calibrated the EM38 with EC_{1:5} for a wide range of soils at 32 sites in the Upper Denmark catchment. They found that 90% of the variability in EC_{1:5} could be explained by ECa. Their EM38 calibration (depth 0.20 - 0.80 m) is:

$$EC_{1:5} = 0.42ECa - 1.74 (R^2 = 0.90)$$

Ferdowsian and Greenham (1992) also examined the ratio between ECe and EC_{1:5}, for different soil textures within their study area. They found that for clayey soils (textures from sandy loam to medium clay), the ratio varied between 9 and 7 respectively. George and Wren (1985) also found that the ratio between ECe and EC_{1:5} was around 8 for clayey soils. Using 8 as the conversion factor to ECe, the calibration of Ferdowsian and Greenham (1992) becomes:

$$ECe = 3.36ECa - 13.92$$

Calibrating ECa with ECe at various depth intervals will also give a measure of the depth of penetration of the instrument signal. In most situations in Western Australia where the EM38 has been calibrated with ECe, it has been found that EM38V is well calibrated with ECe between 0.25 and 1.25 m depth, with EM38H well calibrated between 0.25 and 0.75 m. It may be difficult to obtain reliable calibrations between the EM38 and topsoil (less than 0.25 m deep) salinities because of seasonal fluctuations and the spatial variability of the salinity levels in this zone.

(ii) Clay type and content

Soil ions (other than sodium chloride) that are partially adsorbed to clay colloids can contribute to ionic conductivity. Soils with higher clay contents and cation exchange capacities (CEC) can be more conductive than soils with low clay content at the same salinity. Cation exchange capacity is also dependent on clay type. For example, smectitic clays have higher CEC than illitic clays, which are higher than kaolinitic clays.

Soil porosity, which is related to clay content, can also affect soil electrical conductance. This is because the size and shape of the insulating soil particles (such as sand grains) affect the length of the ionic conducting pathways within the soil matrix, which affects conductivity.

The effect of soil clay content and porosity on ECa can be shown by calibrating ECa with ECe on soils with different clay contents. Figure 1 compares the regressions between soils with different clay contents, the deep sand from Boyup Brook, the heavy loams and clays from the Swan Coastal Plain and the range of soils from the Denmark Catchment (derived from Ferdowsian and Greenham 1992). It can be seen that at higher clay content, the same level of ECa equates with lower ECe.

This may be important when using the EM38 for diagnostic and plant response purposes, because plants will be more tolerant of ECa on very heavy soils than light soils. For these purposes, it is suggested that the EM38 is calibrated with ECe for the particular soil type (see Figure 1).

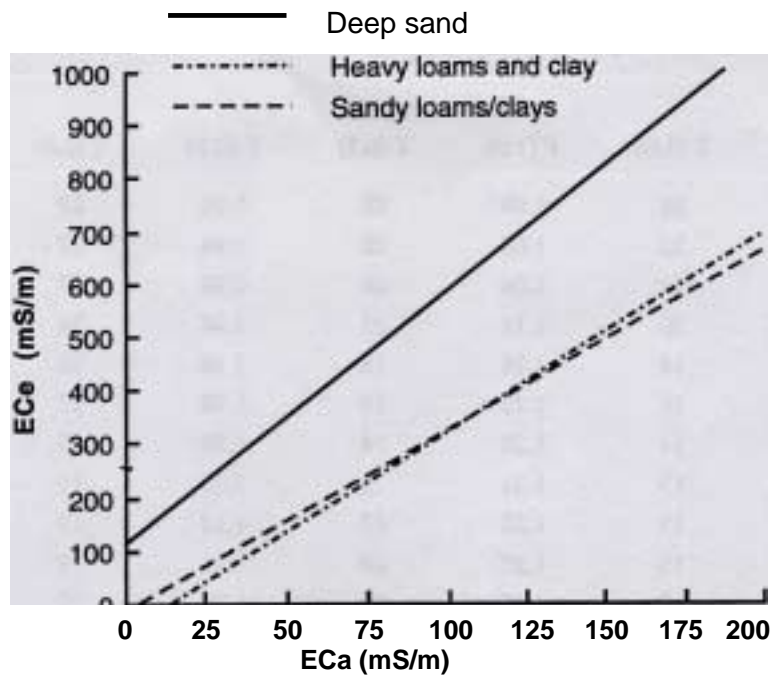

Figure 1. Comparison of EM38 calibrations for different textured soils.

For most applications, soils that have ECa levels above 200 mS/m are too saline for agronomic management and revegetation. Soils having ECa levels below 25 mS/m are regarded as suitable for agricultural crops, pastures and trees.

(iii) Soil moisture

The practical effect of soil moisture on ECa is unclear at low (less than 20%) soil moisture levels. Sufficient soil moisture is required to enable electrical conductivity. However, even field dry soils contain some (the proportion depends on the clay content) hygroscopic water which is tightly bound to the soil colloids and unavailable to plants. This will allow electrical continuity over short distances. For gravimetric moisture levels above 20%, variations in moisture levels have been found to have no effect on the ECa : ECe relationship (Norman, 1990).

In many situations where the EM38 is used to measure salinity on or near saltland, capillary rise from shallow water-tables ensures that the soil will be sufficiently moist throughout most of the year. However, using the EM38 during winter and spring or after significant summer or autumn rainfall is a way of ensuring that low soil moisture will not cause errors, such as low EM38 readings. Measurements of annual salinity changes, induced by management changes, should always be carried out when the soil is at similar moisture content.

(iv) Soil temperature

Soil electrical conductivity is affected by temperature. As a result laboratory measurements of ECe and EC_{1.5} are corrected (using a temperature correction coefficient, T) to a constant soil temperature of 25°C. Therefore, when using the EM38 it may also be important to consider the effect of soil temperature on ECa, particularly if the EM38 is to be used as the only estimate of soil salinity (e.g. to measure salinity changes at a site over a number of years).

Monthly soil temperatures at 0.5 m and 1.0 m depths at Albany and Perth, together with the temperature correction coefficients are given in Table 2. The coefficients for the two depths vary only slightly and can be averaged to correct ECa to 25°C. If not considered, the differences in soil temperature could account for large variations in differences in ECa between seasons (up to 31% at Perth and 25% at Albany).

Calibration of the EM38

The EM38 is especially useful for marking the extent, severity and short-term future spread of saline areas. If used in moderately saline conditions, site specific calibrations may not be necessary. However, calibration is essential if the EM38 readings are to be related to detailed crop or pasture performance

over a range of soils. This is particularly important at low ECa levels, where other soil factors have a greater influence over salinity.

Where calibration is necessary, it should be done at a minimum of 12 sites for each location or major soil type. Select the calibration sites so that a wide range of ECa levels are represented (e.g. between 25 and 200 mS/m). Do not use sites with extreme levels as they may be affected by anomalies. At each site, record EM38V and EM38H and sample the soil in 0.25 m intervals to 2.0 m depth, using a hand auger. Analyse each sample for ECe and correct ECa for temperature (Table 2). Apply linear regressions to the results for each depth interval and combination of intervals to obtain the depth and the relationship that describes the best correlation between ECe and ECa.

Table 2. Average monthly soil temperatures (T) at 0.5 m and 1 m depths for Albany and Perth and the temperature correction coefficient (F) required to correct ECa to 25°C.

Month	Albany				Perth			
	T(0.5)	F(0.5)	T(1.0)	F(1.0)	T(0.5)	F(0.5)	T(1.0)	F(1.0)
<i>Jan</i>	22	1.06	21	1.09	28	0.94	27	0.96
<i>Feb</i>	23	1.04	22	1.06	28	0.94	27	0.96
<i>Mar</i>	22	1.06	22	1.06	26	0.98	27	0.96
<i>Apr</i>	20	1.11	20	1.11	23	1.04	24	1.02
<i>May</i>	16	1.22	18	1.16	18	1.16	20	1.11
<i>Jun</i>	14	1.28	16	1.22	15	1.25	17	1.19
<i>Jul</i>	13	1.31	14	1.28	14	1.28	15	1.25
<i>Aug</i>	13	1.31	13	1.31	15	1.25	15	1.25
<i>Sep</i>	15	1.25	15	1.25	17	1.19	17	1.19
<i>Oct</i>	15	1.25	15	1.25	20	1.11	19	1.14
<i>Nov</i>	18	1.16	17	1.19	23	1.04	22	1.06
<i>Dec</i>	20	1.11	19	1.14	26	0.98	25	1.00

Other considerations for operation

(i) Weather and ground condition

The EM38 should never be used in the rain or in very wet conditions where surface water is present. Use under these conditions could damage the electronic circuitry of the instrument.

(ii) Anomalous readings

The principle of operation of the EM38 assumes lateral homogeneity within the soil profile. If this condition is not met, the instrument may give a false (often very high or negative) reading caused by inversion of the electromagnetic signal. For practical purposes, such conditions may occur if the EM38 is used to measure soil containing large (greater than 0.25 m), discontinuous boulders (especially laterite or dolerite, which contain high proportions of iron) or other buried objects. If non homogeneous conditions are suspected, take two readings in each mode in perpendicular directions (i.e. north-south and east-west) at the same location. If the difference between the two readings in each mode is greater than 5%, ignore the results and move the instrument, repeating the procedure until homogeneous conditions are encountered.

Similarly, non-saline soils rich in ironstone gravels (near lateritic crusts or breakaways) can produce low, negative EM38 readings. These should be interpreted as having very low (or zero) salinity.

(iii) Sodic soils

The clayey horizons of most soils in the agricultural areas of Western Australia are affected to some degree by soil sodicity. Sodic soils are defined as soils having an exchangeable sodium percentage (E.S.P.) greater than 6% (Northcote and Skene 1972). All saline soils are sodic, whereas not all sodic soils are saline, because they can have an excess in sodium ions associated with their clay particles, relative to chloride ions. Unlike chloride ions which can readily leach, sodium ions are relatively immobile in clay soils. In sufficient concentrations, both sodium and chloride are toxic to plants. Ferdowsian and Dollar (1993) further expound on the chemistry of sodic soils.

Table 3. EC_{1.5} of soil from different depths from three sites at Wellstead that have EC_a values exceeding 140 mS/m

Depth(cm)	Site 1	Site 2	Site 3
0	4	10	9
30	4	13	10
60	7	20	38
90	39	51	47

The EM38 will register high values on both sodic (non saline) and saline soils. However, some sodic (non saline) deep **duplex** soils can grow good crops and pastures despite having very high EC_a readings. This is because the sodicity does not affect the sandy A horizon into which the plant roots are confined, however the sodicity of the B horizon is reflected in the EM38 measurement. An example of this effect can be seen in Table 3 which shows the EC_{1.5} levels from three duplex soil sites at Wellstead where the water-table is 10-20 m below ground. The EM38 readings exceed 140 mS/m, yet the sites grow good clover pastures and barley crops.

Despite high EC_a, plant growth is not affected because the root zone (0-60 cm) is sand and has low salinity (as measured by EC_{1.5}). Deeper rooted perennial species, which must explore the B horizon to extract moisture in summer, will be affected by sodicity in similar situations.

Sodic, non-saline soils have been shown to exist in areas of the southern-coastal proterozoic belt at Wellstead and Jerramungup.

When using the EM38 for shallow rooted plant diagnosis or planning purposes, the likelihood of sodic soils affecting EC_a should be assessed. The presence of sodic, duplex soils can be confirmed by soil sampling at different depths and analysing for EC_e or EC_{1.5}. Northcote and Skene (1972) show the various classes and occurrences of sodic soils in Australia.

Instrument operation. Functional checks before use (EM38 model DLM with digital display)

Before use, the EM38 must be checked and zeroed according to the following procedure. Inaccurate zeroing and calibration is by far the largest source of potential error when using the EM38. Perform the following tests on an area of mild to moderate salinity (e.g. where the pasture is composed of dense barley grass with some clover and capeweed) within the proposed survey area. Repeat the tests every two hours and/or at each new site. Refer to Figure 2a for location of the instrument controls.

1. Remove all metal objects (jewellery, watches, boots with steel toe caps or metal sole inserts) and avoid large metal objects in the field - move at least 20 metres away from vehicles, fence lines, pipes and buildings.

2. Battery test:

- (i) Turn the ON/OFF switch to the "BATT" position
- (ii) Turn the RANGE switch to the "1000" mS/m position
- (iii) The battery has sufficient charge if the meter reads greater than 720 (ignore the negative sign)
- (iv) The 9 volt battery is located under the small black panel on top of the instrument
- (v) A new battery allows 30 hours of continuous use

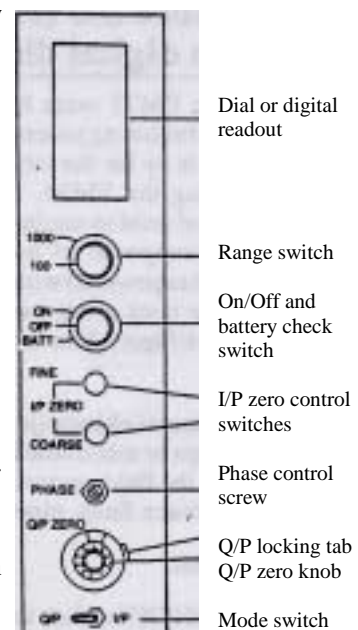

Figure 2a. Location of controls on the EM38.

3. In-phase nulling:

- (i) Check that the RANGE switch is in the "1000" position
- (ii) Move the MODE to the "UP" position
- (iii) Turn the ON/OFF switch to "ON"
- (iv) Lift the EM38 to approximately 1.5 m above the ground (in the horizontal orientation).
- (v) Zero the meter (to +/-10 mS/m) by adjusting first the COARSE and then the FINE I/P ZERO control dials
- (vi) Set the RANGE switch to the "100" position and re-zero the meter, again using the FINE I/P ZERO control dial
- (vii) Return the MODE switch to the "Q/P" position.

4. Instrument zeroing:

- (i) Check that the RANGE switch is on "100" and the MODE switch is in the "Q/P" position
- (ii) Release the Q/P LOCKING TAB by moving it slightly anti-clockwise
- (iii) Lift the EM38 to at least 1.5 m above the ground (the exact height is not important, however the same height must be maintained throughout the whole zeroing procedure)
- (iv) Record the meter reading in the vertical position ("V") and in the horizontal position ("H")
- (v) Adjust the Q/P ZERO dial so that "V" = twice "H" (if "V" is greater than twice "H", increase "H" by "V" minus twice H", if "V" is less than twice "H", decrease "H" by "V minus twice H")
- (vii) Re-check "V" and "H". "V" and "H" must both be positive. "V" and "H" can be any number ("V" is usually much less than 100), however it is critical (to the accuracy of further measurements) that "V" = twice "H" (to +/- 1 mS/m)
- (viii) Re-lock Q/P LOCKING TAB .

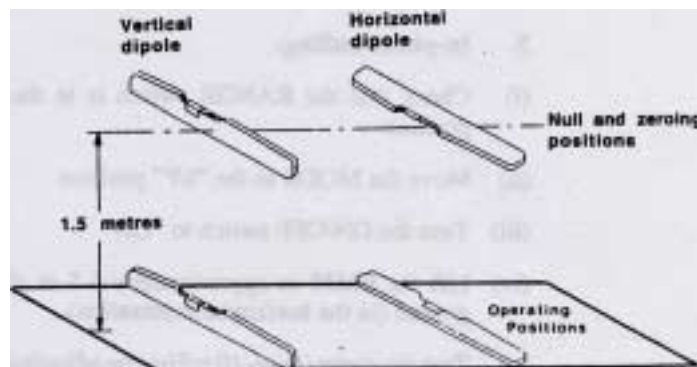

Figure 2b: Zeroing and Operating Positions for the EM38

5. Re check the Inphase nulling (step 3).

6. The instrument is now ready for use.

Note: The phasing and sensitivity of the instrument should be checked every 1 to 3 months, depending on the level of use. Do not attempt to adjust these. One person should be made responsible to do this -

it is not desirable for this to be done as a routine field adjustment by different operators in the field. Also, to ensure that the gain and the electronics of the instrument are not drifting, the EM38 should be tested on a test/Q-coil bench every 6 months. These benches are relatively simple to construct (consult the authors for details), or alternatively the instruments can be returned to the distributor for checking.

Field measurement procedures

1. Leave the EM38 turned "on" at all times during a survey.
2. Turn the EM38 "off" if transporting it in a vehicle.
3. The Mode switch must always be in the "Q/P" position during the survey.
4. Place the EM38 on the ground in the vertical position (i.e. on its edge) and read the meter.
5. Switch the Range switch to the appropriate range (i.e. if the meter is reading less than 100 mS/m - select the "100" range", if the reading is greater than 100, select the "1000" range).
6. Record the vertical reading (the reading is displayed instantly).
7. Turn the EM-38 on its side and record the horizontal reading.
8. The readings are usually recorded in a field book as:
V/H (for example, 182/120)
9. It is critical that the *horizontal value is greater than half the vertical value*. If this is not the case, then electrical or metallic interference is occurring, or the instrument is malfunctioning. The horizontal value can exceed the vertical value.

Paddock surveying

1.0 Grid surveys

Paddock grid surveys are useful for mapping soil salinities and defining salinity boundaries for tree and pasture species with different salt tolerances. Measurements taken on a 50 metre by 20 metre grid pattern will usually give sufficient detail for most purposes.

- 1.1 Place suitable markers (empty fertiliser bags are ideal) at 50 metre intervals along two opposite fences of a paddock to be surveyed. These mark out the ends of the lines that will be surveyed (i.e. during the survey walk between a marker on one fence and the corresponding marker on the opposite fence), so they need to be clearly visible across the paddock. Ideally, you should align the lines so that they cross the most significant saline feature at right angles (for example, position the markers so that the lines will cross a saline creek, and not be parallel to it). This will give better resolution from the survey.
- 1.2 In a notebook, write the line number and survey direction and walk along each line, recording the EM38 readings (vertical and horizontal positions) every 20 metres. The accuracy of spacing between readings can be greatly improved if another person walks in front with a measuring wheel, marking each measurement position by scuffing the ground with their boot.
- 1.3 Once the survey is complete, draw a plan of the surveyed area at a suitable scale. A large sheet of graph paper is ideal because it provides an accurate and consistent scale. On this plan write down the EM38 values recorded in the note book. Use a separate plan for the vertical and horizontal EM38 values.
- 1.4 Contour the soil salinities from the survey area by drawing a line through similar EM38 values on the plan. Useful salinity ranges to identify by contouring are 0-50 mS/m (low salinity), 50-100 mS/m (moderate), 100-150 mS/m (high) and greater than 150 mS/m (severe salinity). Specialist computer programs (including the GIS system) are available which will process and print contour maps of salinities from grid surveys. Specialist geophysical processing companies can also be contracted to produce contour plans from grid surveys.
- 1.5 The final salinity contour plans should be transposed onto aerial photographs or farm plans to assist with farm planning and selection of the appropriate pasture or tree species for the area.

2.0 Transect surveys

Transect paddock surveys are useful for measuring salinity changes over time (e.g. to measure the effect of a treatment). Larger scale transect surveys can be useful for estimating the location and extent of salinity in a catchment or district and can be re-measured to provide information on district trends.

- 2.1 Paddock transects should be accurately and permanently marked with end pegs that are clearly visible for the full length of the transect. Using additional sighter pegs placed along the

transect will help maintain direction during the survey. Measurement spacings can be between 1 m (maximum resolution) and 10 m (long transects).

- 2.2 District transects may traverse roads, fences and several properties so permanent marking is impractical. Instead, first chose a representative and convenient route, using aerial photos, that follows permanent features such as roads or several property boundaries. Then at convenient line of sight intervals (internal fences are useful), place temporary markers (empty fertiliser bags etc) 50 m into the paddock from the permanent features. During the survey, line up the markers to obtain the transect line. 20 m measurement intervals are sufficient for district surveys.

Acknowledgements

The authors thank Don Mcparlane, Ruhi Ferdowsian, Stephen Vlahos and Chris Norman for their input and constructive criticism during the preparation of this report.

References and further reading

Anon. (1992). Geonics EM38 ground conductivity meter operating manual. Geonics Limited, Ontario, Canada.

Barrett-Lennard, E.G. (1986). Effects of waterlogging on the growth and sodium chloride uptake by vascular plants under saline conditions. *Reclamation and Revegetation Research*, 5: 245-61.

Bennett, D.L. and George, R.J. (in press). Using the EM38 to measure the effect of soil salinity on *Eucalyptus globulus* in south-western Australia. *Agricultural Water Management*.

Daubenmire, R.F. (1974). Plants and environment. John Wiley and Sons, Canada.

Ferdowsian, R. and Dellar, G. (1993). Sodic Soils. Technote No. 14/93. Western Australian Department of Agriculture.

Ferdowsian, R. and Greenham, K. (1992). Integrated catchment management: Upper Denmark Catchment. Technical Report No. 130. Western Australian Department of Agriculture.

George, P.R. and Wren, B.A. (1985). Crop tolerance to soil salinity. Technote No. 6/85. Western Australian Department of Agriculture.

Lesch, S.M., Rhoades, J.D., Lund, L.J. and Corwin, D.L. (1992). Mapping soil salinity using calibrated electronic measurements. *Soil Science Society of America Journal*, 56:540-8.

McNeill, J.D. (1980a). Electrical conductivity of soils and rocks. Technical Note TN-5, Geonics Limited, Ontario, Canada.

McNeill, J.D. (1980b). Electromagnetic terrain conductivity at low induction numbers. Technical Note TN-6, Geonics Limited, Ontario, Canada.

Norman, C. (1990). Training manual on the use of the EM38 for soil salinity appraisal. No. 181. Department of Agriculture and Rural Affairs, Victoria.

Northcote, K.H. and Skene, J.K.M. (1972). Australian soils with saline and sodic properties. Soil Publication No. 27, CSIRO, Australia.

Richards L.A. (Editor). 1954. Diagnosis and improvement of saline and alkali soils. Handbook No. 60. United States Dept of Agriculture.